

SPECIALE TAPPARELLE & AVVOLGITORI

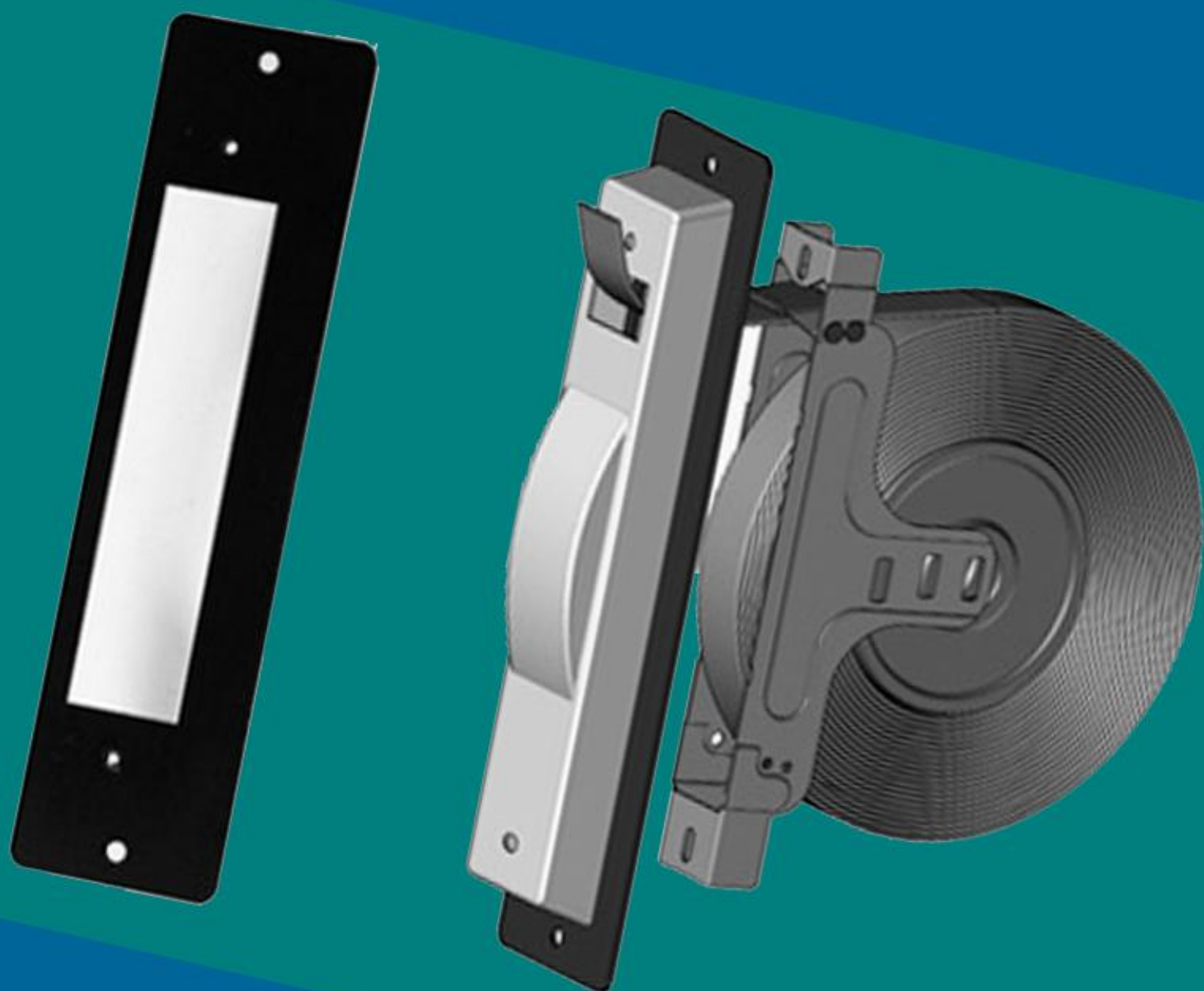

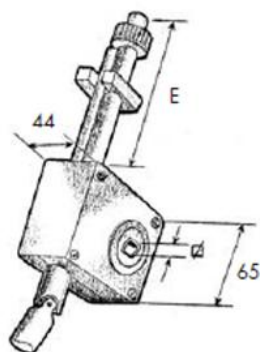

ARGANELLI



rap. 1:8 - 10
max imp. Kg. 30

rap. 1:13 - 13
max imp. Kg. 50

rap. 1:16 - 13
max imp. Kg. 70

Arganello "Strong" senza fine corsa
spessore 44mm.

"Strong" winch without end strok
Treuil "Strong" sans fin de course
Getriebe "Strong" ohne anschlag

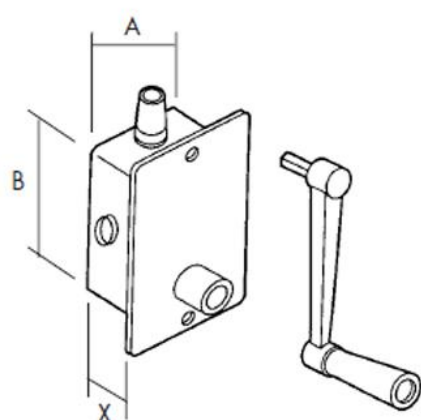

rap. 1:2 - Kg. 45
A = 73
B = 111
X = 38

rap. 1:3 - Kg. 80
A = 98
B = 138,5
X = 46,5

Arganello "SP" incasso a fune,
placca e maniglia alu
"SP" Inside rope winch alu covering plate
and handle

Treuil a cable a encastrer
plaque et manivelle en aluminium
Unterputz-seilwinde
mit Abdeckplatte unt kurbel aus Aluminium

20

10

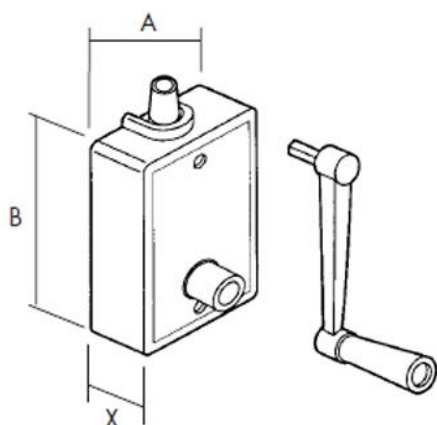

rap. 1:2 - Kg. 45
A = 85,5
B = 115
X = 42

rap. 1:3 - Kg. 80
A = 104
B = 143,5
X = 52

Arganello "SP" esterno a fune
con placca e maniglia alu
"SP" outside rope winch with alu covering plate
and handle

Treuil a cable apparent
avec plaque et manivelle
Aufputz-Seilwinde
mit Abdeckplatte unt kurbel aus Kunststoff

20

10

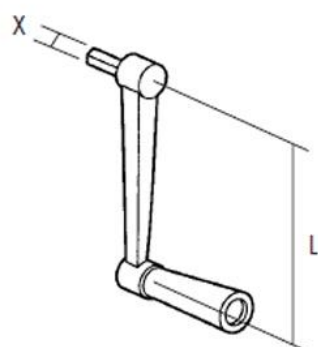

L = 125
X = es. 9

L = 125
X = 8

L = 160
X = es. 9

Maniglia alu per argano a fune "SP"
Alu handle for "SP" winch
Manivelle alu pour treuil "SP"
Kurbel alu fur getriebe

100

100

100



ARGANELLI

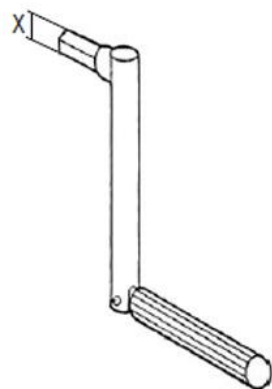

L = 80
L = 120
L = 140
L = 80
X = $\varnothing 8/\varnothing 16$
ES. 9/ ES. 7

Maniglia cromata per argano cinghia/cordone "BGM"	50
Chromed handle for winch	50
Manivelle decie pour treuil	50
Colori / Colors / Couleurs:	
avorio - bianco - nero	?
vory - white - black	
ivoire - blanc - noire	

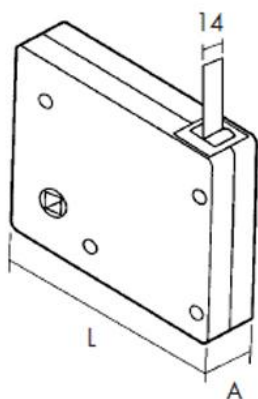

Con cintino mini
14 mm. x 5 mt.
A = 32
L = 150

Arganello mini a cinghia Mini strap winch with plastic case Mini-treuil a sangle avec boitier en plastique Mini-Kurbelwickler fuer gurt mit Gehaeuse aus Kunststoff	20
---	----

Senza cintino
Without strap

Colori / Colours / Couleurs / Farbe:	
bianco 31 - marrone 33	
white 31 - brown 33	20
blanc 31 - brun 33	
weiss 31 - braun 33	

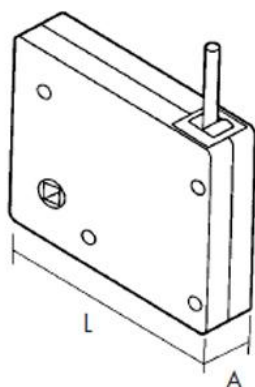

Con cordone
With braid
mt. rap. 1:3
A = 32
L = 152

Arganello mini a cordone $\varnothing 4,5$ Braid mini-winch with plastic case Mini-treuil a cordon avec boitier en plastique Mini-Kurbelwickler fuer schnur mit Gehaeuse aus Kunststoff	20
---	----

Senza cordone
Without braid

Colori / Colours / Couleurs / Farbe:	
bianco 31 - marrone 33	
white 31 - brown 33	20
blanc 31 - brun 33	
weiss 31 - braun 33	

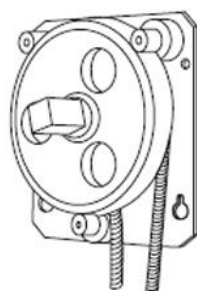

Sinistro frizionato
Left
Gauche
Links

Destro frizionato
Right
Droite
Rechts

Cordone continuo "Easy lift" kg. 25 completo di calotta e guidacordone "Easy lift" gear kg. 25 with cap and braid guide Treuil a cordon	25
	25

AVV.PLACCHE CASSETTE

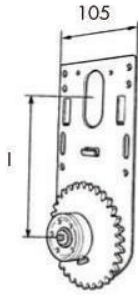

l = 112,5
DX E SX

Avvolgitore "Compact Beta"
"Compact Beta" Strap coiler
Enrouleur "Compact Beta"
Wickler "Compact Beta"

25

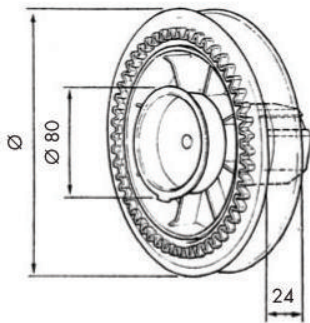

Ø = 180
DX E SX

Puleggia con cintino 20mm.
per "Compact Beta"
"Compact Beta"
pulley with strap 20mm.
Poulie avec sangle 20mm.
pour "Compact Beta"
Gurtscheibe mit gurt 20mm.
für "Compact Beta"

25

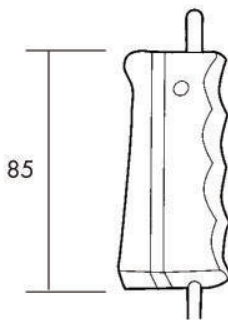

Maniglia per cordone Ø 3mm.
Handle for braid Ø 3mm.
Poignée pour cordon
Kurlben für Schnur

50

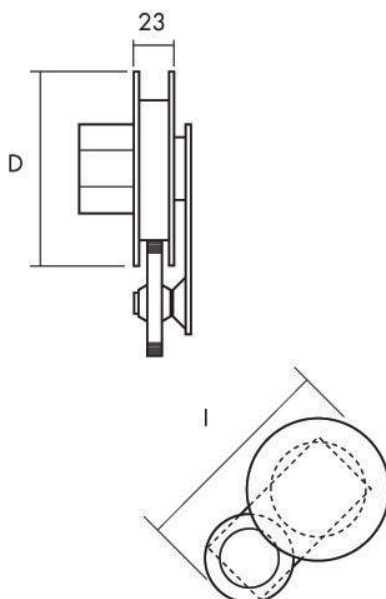

l = 20
D = 14

Avvolgitore a cassonetto Ø140 - Puleggia F/Z
Coiler into the box with steel pulley

50

D = 18

Avvolgitore a cassonetto Ø180 - Puleggia F/Z
Coiler into the box with steel pulley

50

D = 20

Avvolgitore a cassonetto Ø200 - Puleggia F/Z
Coiler into the box with steel pulley

50

D = 16

Avvolgitore a cassonetto con riduttore Ø160
Reduction coiler into the box

50

D = 18

Avvolgitore a cassonetto con riduttore Ø180
Reduction coiler into the box

50

D = 13,5

Avvolgitore a cassonetto Ø135 - Puleggia PVC
Coiler into the box - PVC pulley

50

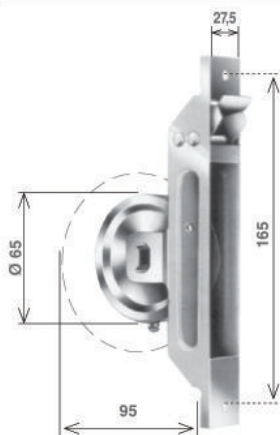

SERIE "S-5"
"S-5" SERIES

Avvolgitore a semincasso «S» 5 m «S» half-embedded coiler 5 m			Spessore telo Slat thickness	14 mm	9 mm
	<i>Nota - Remark</i>		H max Max. height	2,50 m	2,50 m
	non caricati spring not wound-up	50	Ø max pul. (mm) Ø max pulley (mm)	220	200
	con molla caricata with wound-up spring	50	Cintino (mm) Strap (mm)	22x1,7	22x1,7



	con 6 m di cintino 22x1,7 mm with 6 m strap 22x1,7 mm	Colore cintino - Strap colour	
		avorio - ivory	50
		grigio - grey	50

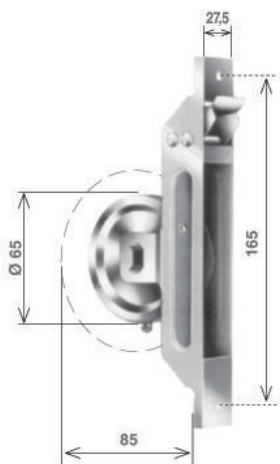

SERIE "S-5" A MINIMO INGOMBRO
"S-5" SERIES - COMPACT

Avvolgitore a semincasso «S» 5 m «S» half-embedded coiler 5 m			Spessore telo Slat thickness	14 mm	9 mm
	<i>Nota - Remark</i>		H max Max. height	2,50 m	2,50 m
	non caricati spring not wound-up	50	Ø max pul. (mm) Ø max pulley (mm)	220	200
	con molla caricata with wound-up spring	50	Cintino (mm) Strap (mm)	20x1,2	20x1,2



	con 5,5 m di cintino 20x1,2 mm with 5,5 m strap 20x1,2 mm	Colore cintino - Strap colour	
		avorio - ivory	50
		grigio - grey	50



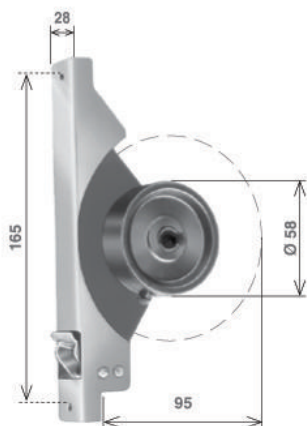

SERIE "SP-5"
"SP-5" SERIES

Avvolgitore a semincasso «SP» 5 m «SP» half-embedded coiler 5 m			Spessore telo Slat thickness	14 mm	9 mm
	<i>Nota - Remark</i>		H max <i>max height</i>	2,50 m	2,50 m
	non caricati spring not wound-up	50	Ø max pul. (mm) <i>Ø max pulley (mm)</i>	220	200
	con molla caricata with wound-up spring	50	Cintino (mm) <i>Strap (mm)</i>	20x1,2	20x1,2

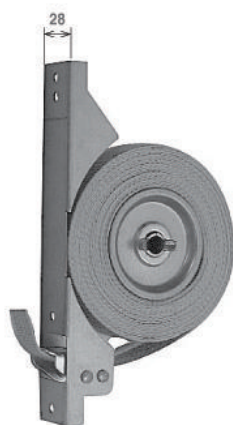

	con 5,5 m di cintino 20x1,2 mm with 5,5 m strap 20x1,2 mm	<i>Colore cintino - Strap colour</i>	
		avorio - <i>ivory</i>	50
		grigio - <i>grey</i>	50

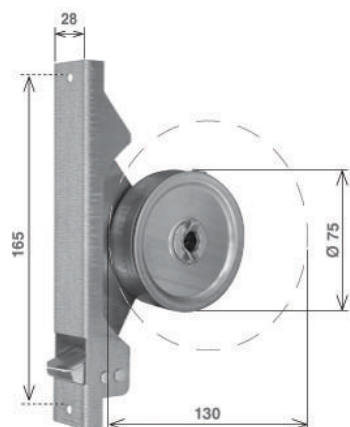

SERIE "SP-8" PER RIDUTTORE
"SP-8" SERIES FOR REDUCTION GEAR

Avvolgitore a semincasso «SP» con molla caricata 8 m «SP» half-embedded coiler with wound-up spring 8 m			Spessore telo Slat thickness	14 mm	9 mm
	<i>Finiture - Finishes</i>		H max	2,50 m	2,10 m
	zincato galvanized	50	Riduttore <i>Reduction gear</i>	art. 058-063	art. 058-063
			Cintino (mm) <i>Strap (mm)</i>	20x1,2	20x1,2

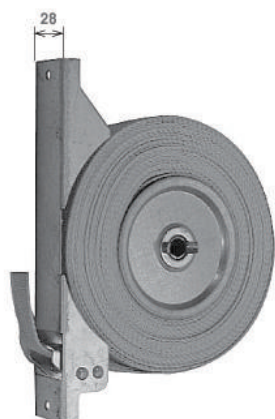

	con 10 m di cintino 20x1,2 mm with 10 m strap 20x1,2 mm	<i>Colore cintino - Strap colour</i>	
		avorio - <i>ivory</i>	50
		grigio - <i>grey</i>	50

PULEGGE & RIDUTTORI

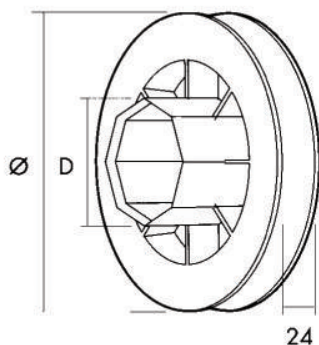

- Ø 155 - D 60
- Ø 175 - D 60
- Ø 195 - D 60
- Ø 215 - D 60

Puleggia regolabile in plastica	100
Adjustable plastic pulley	100
Poulie réglable en plastique	100
Verstellbare Gurtscheibe aus Kunststoff	100

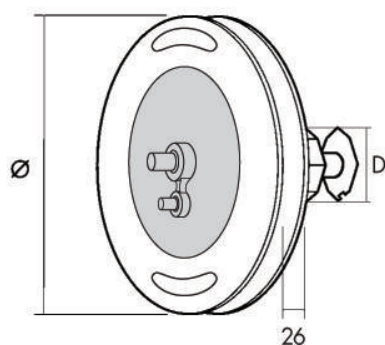

- Ø 210 - D 60
- Ø 240 - D 60
- Ø 210 - D 60
- Ø 240 - D 60

Riduttore in acciaio "Standard"	15
senza supporto	15
Steel strap reduction gear	
Demultiplicateur en acier	15
Gurtzuggetriebe aus Stahl	15

* Riduttore con supporto A4360

Rapporto di trasmissione: 1:2,5
Ratio: 1:2,5
Rapport: 1:2,5
Untersetzung: 1:2,5

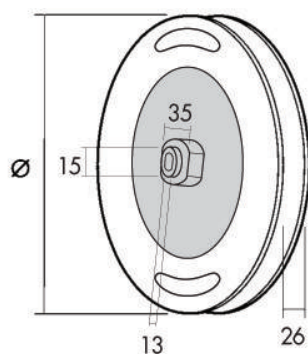

- Ø 160
- Ø 190
- Ø 210

Riduttore in acciaio "Export"	50
Steel strap reduction gear	
Demultiplicateur en acier	
Gurtzuggetriebe aus Stahl	

Rapporto di trasmissione: 1:2
Ratio - Rapport - Untersetzung: 1:2

Supporto - Bracket - Support: A4364 - A4580

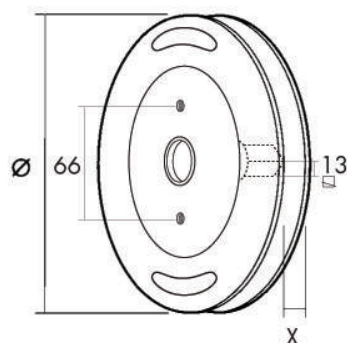

- Ø 125 - X = 16
- Ø 140 - X = 16
- Ø 155 - X = 16
- Ø 170 - X = 16
- Ø 180 - X = 24

Mini-riduttore 1:2 con perno	25
Mini-strap reduction gear 1:2 with pivot	25
Mini-demultiplicateur 1:2 avec pivot	25
Mini-gurtzuggetriebe 1:2 mit Stift	25
	25